

Instruction Manual
for your new i-Car™
speaker system.

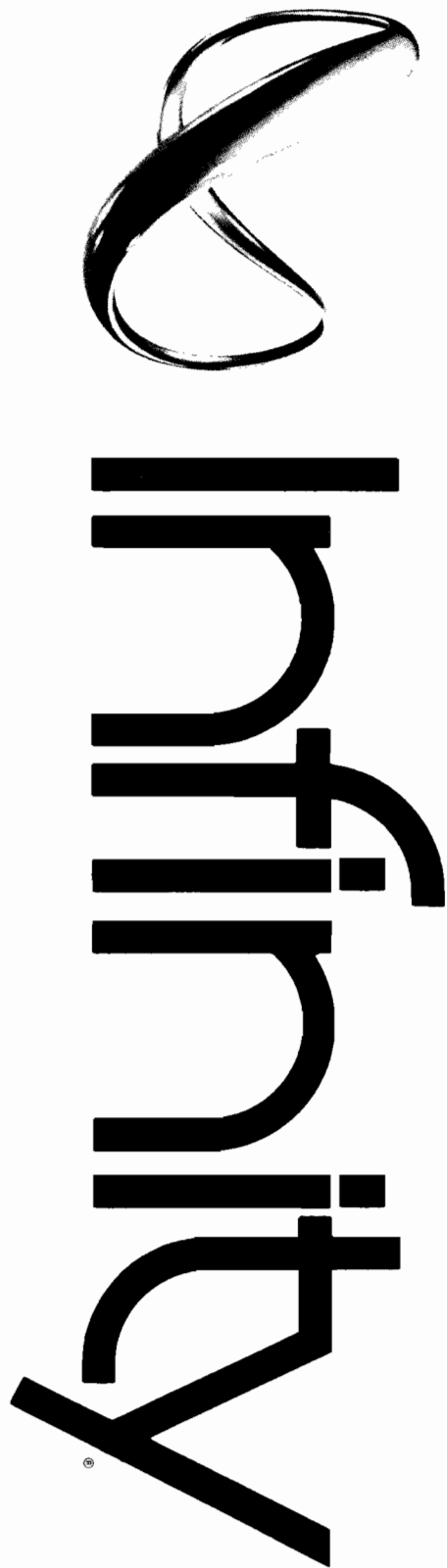

Audiophile fidelity for the autophile.

Since you love music on the road as much as you care about music at home, Infinity has created the speaker you've been listening for: i-Car. An automotive application of the same Infinity home speaker technology that has redefined the state-of-the-art. Like all Infinity speakers, i-Car will not color the music with a characteristic "speaker" sound. Rather, it is designed to reproduce music with faithful accuracy to the original recording. Calling i-Car a car speaker is an understatement. It should really be called a moving experience.

Associated components.

Your i-Car is a high quality, high fidelity system, and will work best when used with other top quality components. Since i-Car will reproduce distortion just as accurately as music, it will not perform satisfactorily with low-power or sub-standard car radios or tape players (these may even damage your i-Car). For best performance, your amplifier or booster should be able to provide at least 10 watts per channel into a 4 ohm load. The maximum recommended power for i-Car is 100 watts per channel.

Unpacking.

Check your speakers carefully. If they have been damaged in transit, call your dealer and/or the freight company at once. Keep the packaging, in case you need to ship your speakers in the future. The i-Car package should contain the following items (part nos. in parenthesis):

- Two i-Car speaker assemblies (910075).
- One hardware kit No. 1 (503902) with spare fuses 1¼ AGC (412004).
- One hardware kit No. 2 (503903).

Choose the best mounting location.

If the speakers are to be used in a car (rather than a van or boat) there are two optimum locations: The rear parcel shelf, or the front door panels. Each is suitable, but for best balance the rear package shelf is preferable, especially in cars which carry rear seated passengers. CAUTION: Water sometimes leaks inside doors which can badly damage your i-Car (see warranty). If rust, stains, or other evidence of leaks are evident, avoid the affected area. A less ideal location is in the side kick panels (beside the doors under the dashboard).

Many cars already have standard mounting "cutouts" in these locations, which make installation easier.

Before mounting the speakers in a selected location, check to see that a cable route exists from your amplifier. Typical routes are under carpets, along transmission tunnels, and along door sills at the bottom of door

frames. If cables are already built into your car, the wire must be heavy enough to carry the high power (16 gauge or heavier). Do NOT use ready-installed existing cables if either wire is connected to the car's metal frame.

Make sure there is space in front as well as behind the mounting surface for the i-Car to fit (with spacer if required). There must be enough space in front to allow the grille to be screwed in place after installation, and the fuse to be changed if needed. Behind the i-Car, moving parts such as trunk lid springs, torsion rods, door lock mechanisms, and window gears must not interfere with the speaker. The i-Car electrical connections should not be touching any metal part of the car. In general, the more clear space directly behind the speaker, the better.

Use the spacer plate under the speaker whenever possible to improve sound quality by inclining the axis of the speaker towards the passengers. On the parcel shelf, locate the EMIT tweeters toward the center of the car. On the doors or kick panels, locate the EMIT tweeters away from the floor (Fig. 1).

If you have access to the rear of the mounting surface you may attach i-Car from the back. This makes theft more difficult; but this method may not be used with the spacer.

Fig. 1

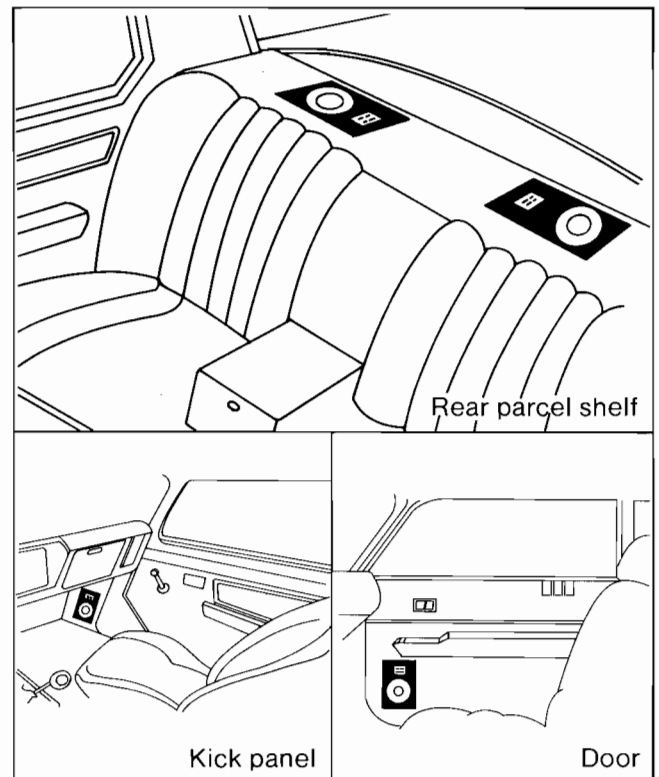

Installation.

Having chosen the best location, begin installation. Do not discard any screws until installation is complete.

1. Detach the grille from each speaker by removing the two mounting screws (Fig. 2).
2. Detach the spacers by removing the four mounting screws from the corners of the speaker baffle (Fig. 3).

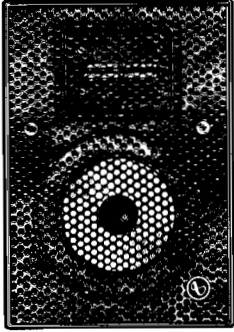

Fig. 2



Fig. 3

3. At the mounting location, be certain there is adequate clearance both behind and in front of the mounted i-Car (with spacer if to be used), and that you have a cable route to the amplifier. Take particular care that i-Car terminals, fuseholder, and circuit board will not touch the car's metalwork.

4. A variety of lengths of screws is supplied for different mounting surfaces, including sheet metal/wood screws. Choose the correct set of instructions for your mounting hole size below, and continue:

A. If you are using existing 6x9 in. standard cutouts:

Use TEMPLATE "A" from this booklet. Place the template precisely over the 6x9-inch cutout and trace the screw hole locations onto the mounting surface. Use the 4 BLACK hole marks if you plan to use the spacer; use the 4 WHITE hole marks if no spacer is required; use the 4 STARRED hole marks if you plan to screw the i-Car in place from the back.

Drill the screw holes using a 1/4 in. drill bit. If using the spacer, mount it using hardware kit No. 1 (Fig. 4). Proceed to step 5 below.

B. If you are using existing 5 in. standard cutouts:

Use TEMPLATE "B" from this booklet. Place the template precisely over the 5-inch hole and orient it the direction you want i-Car and spacer to face. Trace the 3 screw hole locations onto the mounting surface.

Drill the screw holes using a 1/4 in. drill bit. You must use the spacer, mount it with hardware kit No. 1 (Fig. 4). Proceed to step 5 below.

C. If you have no existing standard cutouts:

If you must cut your own cutout holes, use the 5-inch cutout (template "B"), or the 6x9 in. cutout (template "A"). Note that if you choose 5-inch cutouts you must use the spacer to mount i-Car. Whichever you choose, position the template and trace the hole shape onto the mounting surface. Save the template.

Cut the mounting hole. If you used template "A," continue with step A above. If you used template "B," continue with step B above.

5. Route cables from the amplifier to speaker locations. Use 16 gauge or heavier wire.
6. Connect the cables to the i-Car terminals, being certain to maintain polarity: "HOT" or "+" on the amplifier connects to the RED terminal on i-Car.
7. Position the i-Car over the hole, taking care that the terminals, fuseholder, and circuit board will not touch any metal parts of the car. If in doubt, use heavy electrical tape to ensure insulation.
8. To screw the i-Car in place:
 - A. If using the spacer, follow Fig. 4 and use the screws removed in step 2.
 - B. If not using the spacer, follow Fig. 5 and use hardware kit No. 1.
 - C. If securing the i-Car from behind, follow Fig. 6 and use hardware kit No. 2.
9. Attach the grille using the screws removed in step 1.

Fig. 4

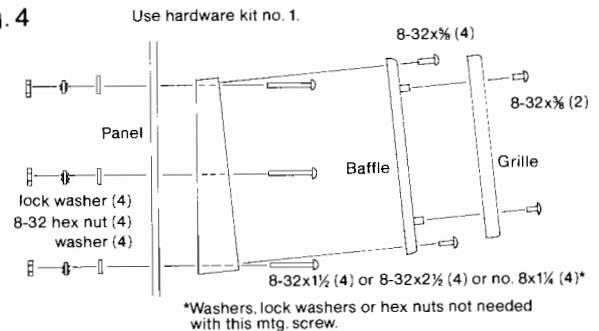

Fuses.

The i-Car is fused to protect the EMIT tweeter. If the fuse should fail there will be a loss of high frequencies. Remove the grille to gain access to the fuse. **DO NOT REPLACE THE FUSE EXCEPT WITH ONE RATED 1¼ AGC—FAST-BLO.** The fuse may fail for several reasons:

A. Fatigue: After a year or more of continued use the fuse may fail from fatigue. Provided this occurs infrequently, there is no reason for concern.

B. Overload: In the presence of very high power, the fuse may fail. **DO NOT USE EXCESSIVE TREBLE BOOST**, it is not necessary with the i-Car and may damage any fine speaker.

C. Fault: The fuse will blow persistently if there is a fault, such as amplifier failure. Do not continue to use equipment if persistent fuse failure occurs.

Automobile ignition noise.

Radios and amplifiers may pick up noise from your car's electrical system. High fidelity speakers reproduce this interference better than standard car radio speakers. If your system produces interference since you added the i-Cars, it is almost certainly not the speaker installation which is causing the problem; most probably, your previous speakers failed to reproduce the interference. Installing ignition noise suppression equipment on your car's electrical system will reduce this problem.

Fig. 5

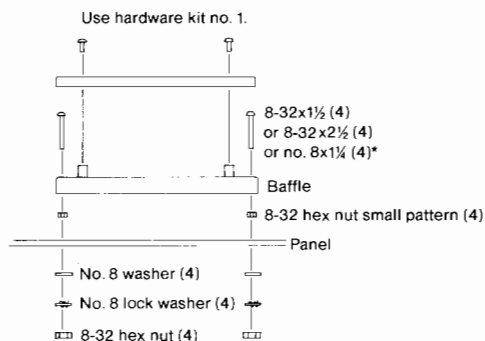

*Small or standard pattern hex nuts, washers or lock washers not needed with this mtg. screw.

In case of trouble.

If your i-Cars are not working satisfactorily, contact your Infinity dealer, who will advise you on the quickest way to have them checked over and repaired. If in difficulty, contact the factory for the name of your nearest authorized service station. Service under the terms of the warranty is available from any authorized service station, irrespective of where the product was first purchased.

SPECIFICATIONS

Frequency response:
40-32,000 Hz.

Crossover frequency:
3000 Hz.

Recommended power:
15 to 100 watts per channel.

Drivers:
EMIT (Electromagnetic Induction Tweeter). Fused.
5-inch (12 cm) woofer with polypropylene cone.

Nominal impedance:
4 ohms.

Dimensions:
9¼" (23.5 cm) x 6¼" (16 cm) wide. Depth from back of frame: 2⅛" (5.4 cm).

Weight:
Approximately 3 lbs.

Finish:
Frame: ABS glass-filled plastic, black.
Perforated aluminum grille, black.

Fuse: 1¼ AGC fast-blo.

Because Infinity strives always to improve existing products, specifications are subject to change without notice.

Fig. 6

